

GAS STOCKPOT STOVE



Art.-Nr. 329220 / EAN 4064801002874 / Preis gemäß Preisliste

BASIC FEATURES:

- ✦ made of stainless steel
- ✦ durable construction adjusted to heavy loads
- ✦ high-power, efficient and energy saving burner
- ✦ burner power adjustment from economic position (25% of flow capacity) until complete valve opening
- ✦ burner with control flame
- ✦ removable, cast-iron pan support
- ✦ protection of the gas valve knob against mechanical damage (the knob does not stick out of the body)
- ✦ gas anti-outflow protection
- ✦ designed for large pots, max. Ø50 cm
- ✦ max load: 100 kg
- ✦ gas inlet: R $\frac{1}{2}$ "

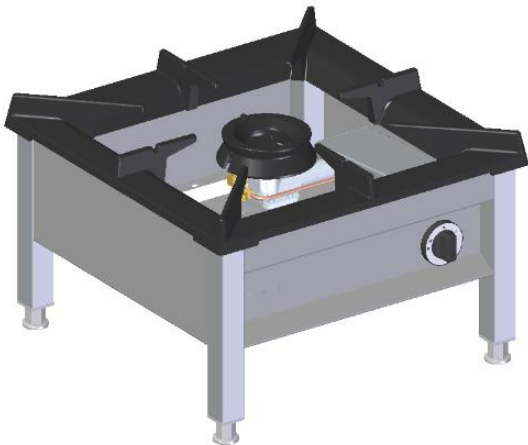

HGT19-057DK

TECHNICAL DATA:

Model	HGT19-057DK	
Width	[mm]	566
Depth	[mm]	566
Height	[mm]	385
Total power	[kW]	13
Gas inlet	R 1/2"	
Gas type	G20; G2.350; G27; G30/G31	
Net weight	[kg]	30
Max load	[kg]	100

